

Technical Data Sheet Top Phototransistor PT67-21B/C14/TR8

Features

- Fast response time
- High photo sensitivity
- Small junction capacitance
- Package in 8mm tape on 7" diameter reels.
- Compatible with infrared and vapor phase reflow solder process.
- Pb free
- The product itself will remain within RoHS compliant version.
- Compliance with EU REACH.
- Compliance Halogen Free .(Br <900 ppm ,Cl <900 ppm , Br+Cl < 1500 ppm)

Description

• PT67-21B/C14/TR8 is a high speed silicon NPN epitaxial planar phototransistor in a compact surface-mountable package. It's compatible with automatic placement equipment and can withstand IR reflow, vapor phase reflow , and wave solder processes.

Applications

- Miniature switch
- Counters and sorter
- Position sensor
- Infrared applied system

Device Selection Guide

Device No.	Chip Material	Lens Color
PT67-21B/C14/TR8	Silicon	Black

Package Dimensions

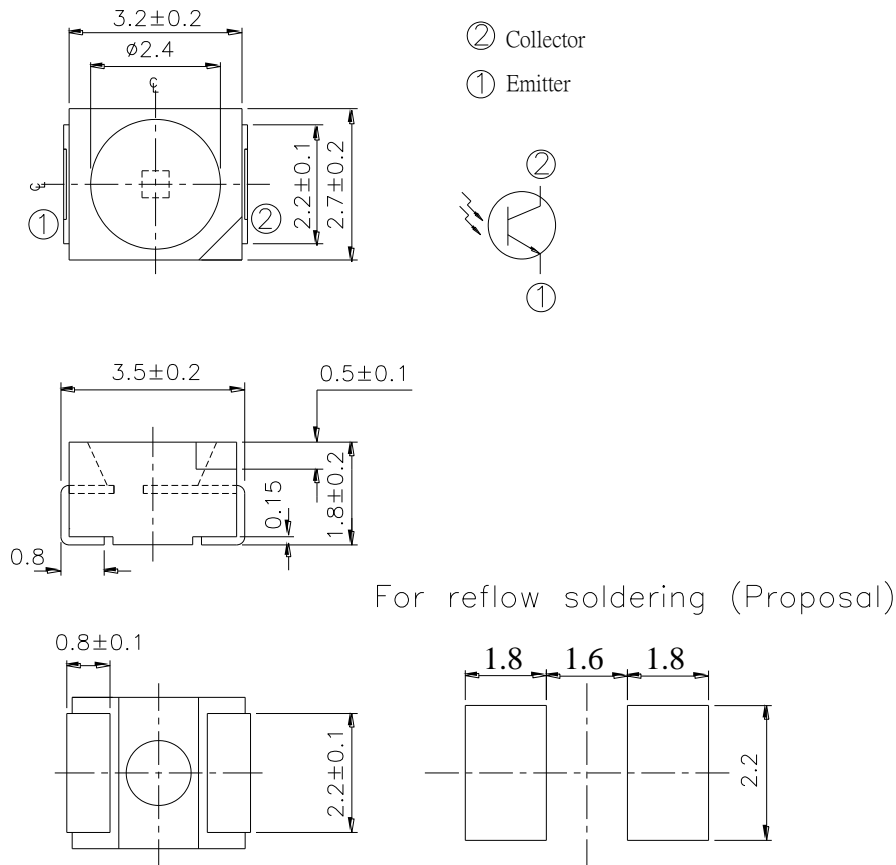

Absolute Maximum Ratings (Ta=25°C)

Parameter	Symbol	Rating	Unit
Collector-Emitter Voltage	V_{CEO}	30	V
Emitter-Collector-Voltage	V_{ECO}	5	V
Collector Current	I_C	20	mA
Operating Temperature	T_{opr}	-40 ~ +85	°C
Storage Temperature	T_{stg}	-40 ~ +100	°C
Soldering Temperature	T_{sol}	260	°C
Power Dissipation at(or below) 25°C Free Air Temperature	P_c	75	mW

Notes: *1:Soldering time \leq 5 seconds.

Electro-Optical Characteristics (Ta=25°C)

Parameter	Symbol	Min.	Typ.	Max.	Unit	Condition
Rang Of Spectral Bandwidth	$\lambda_{0.5}$	700	---	1100	nm	---
Wavelength Of Peak Sensitivity	λ_P	---	940	---	nm	---
Collector-Emitter Breakdown Voltage	BV_{CEO}	30	---	---	V	$I_C=100\mu A$ $E_e=0mW/cm^2$
Emitter-Collector Breakdown Voltage	BV_{ECO}	5	---	---	V	$I_E=100\mu A$ $E_e=0mW/cm^2$
Collector-Emitter Saturation Voltage	$V_{CE(sat)}$	---	---	0.4	V	$I_C=2mA$ $E_e=1mW/cm^2$
Collector Dark Current	I_{CEO}	---	---	100	nA	$V_{CE}=20V$ $E_e=0mW/cm^2$
On State Collector Current	$I_{C(ON)}$	16	---	80	μA	$V_{CE}=5V$ $E_e=0.1mW/cm^2$
Rise Time	t_r	---	15	---	μS	$V_{CE}=5V$ $I_C=1mA$ $R_L=1000\Omega$
Fall Time	t_f	---	15	---		

Rank

Condition : $V_{CE}=5V, E_e=0.1mW/cm^2$

Unit : μA

Bin Number	Bin2	Bin3	Bin4
Min	16	25	40
Max	32	50	80

业务技术咨询 : TEL/微信: 13422876592

Typical Electrical/Optical/Characteristics Curves for IR

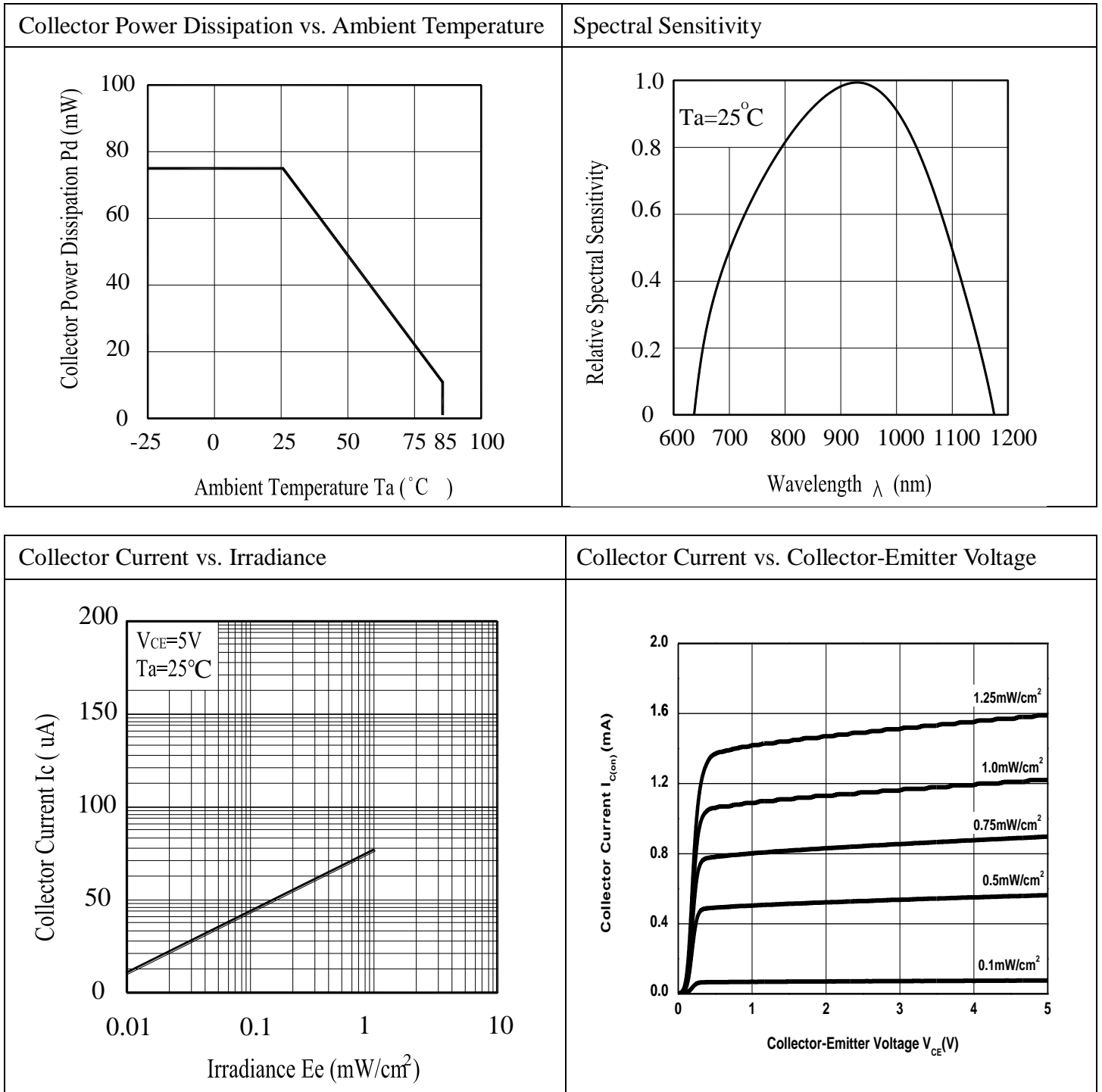

Precautions For Use

1. Over-current-proof

Customer must apply resistors for protection , otherwise slight voltage shift will cause big current change (Burn out will happen).

2. Storage

2.1 Do not open moisture proof bag before the products are ready to use.

2.2 Before opening the package, the Phototransistor should be kept at 30°C or less and 90%RH or less.

2.3 The Phototransistor should be used within a year.

2.4 After opening the package, the Phototransistor should be kept at 30°C or less and 70%RH or less.

2.5 The Phototransistor should be used within 168 hours (7 days) after opening the package

2.6 If the moisture absorbent material (silica gel) has faded away or the Phototransistor have exceeded the storage time, baking treatment should be performed using the following conditions.

Baking treatment : $60\pm 5^{\circ}\text{C}$ for Min 24 hours.

3. Soldering Condition

3.1 Pb-free solder temperature profile

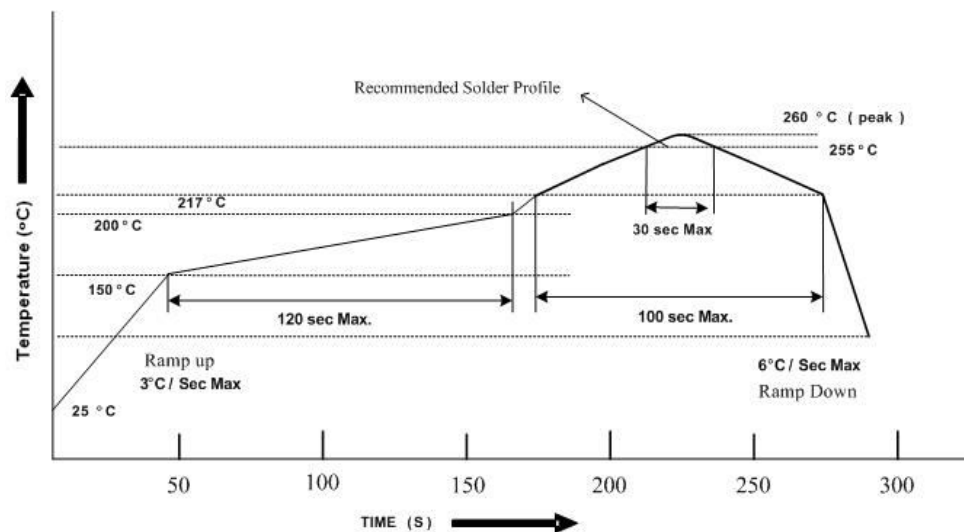

3.2 Reflow soldering should not be done more than two times.

3.3 When soldering, do not put stress on the Phototransistor during heating.

3.4 After soldering, do not warp the circuit board.

4. Soldering Iron

Each terminal is to go to the tip of soldering iron temperature less than 350°C for 3 seconds within once in less than the soldering iron capacity 25W. Leave two seconds and more intervals, and do soldering of each terminal. Be careful because the damage of the product is often started at the time of the hand solder.

5. Repairing

Repair should not be done after the Phototransistor have been soldered. When repairing is unavoidable, a double-head soldering iron should be used (as below figure). It should be confirmed beforehand whether the characteristics of the Phototransistor will or will not be damaged by repairing.

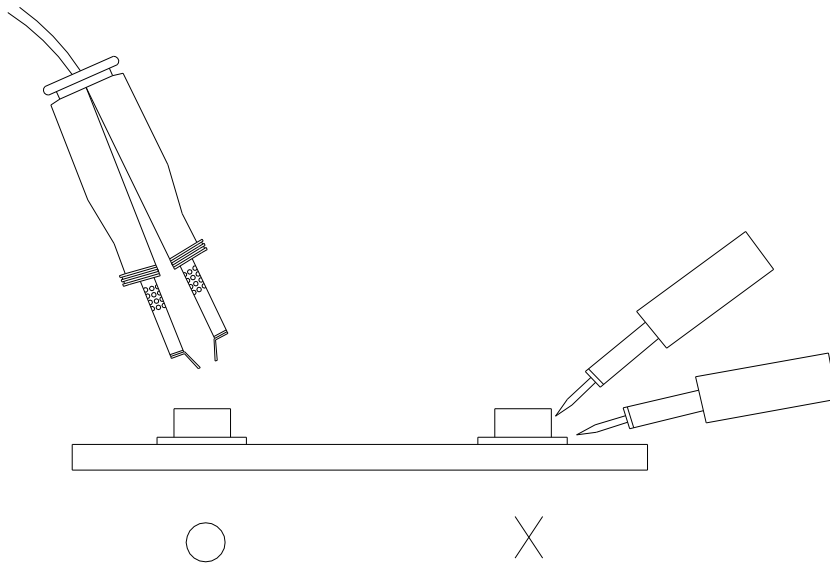

Package Dimensions

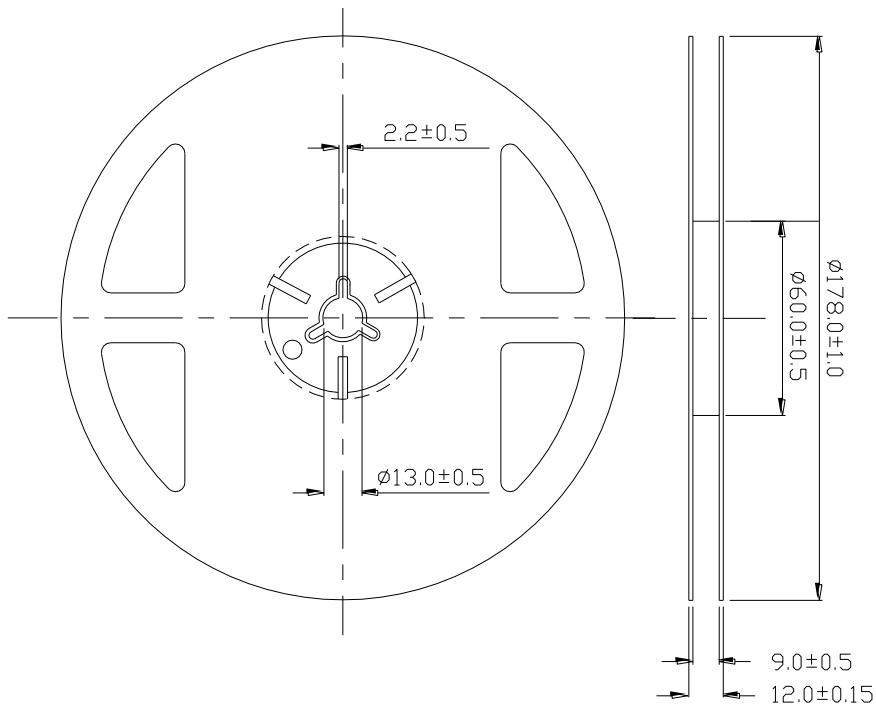

Note: The tolerances unless mentioned is ± 0.1 mm ,Unit = mm

Carrier Tape Dimensions:(Quantity: 2000pcs/reel)

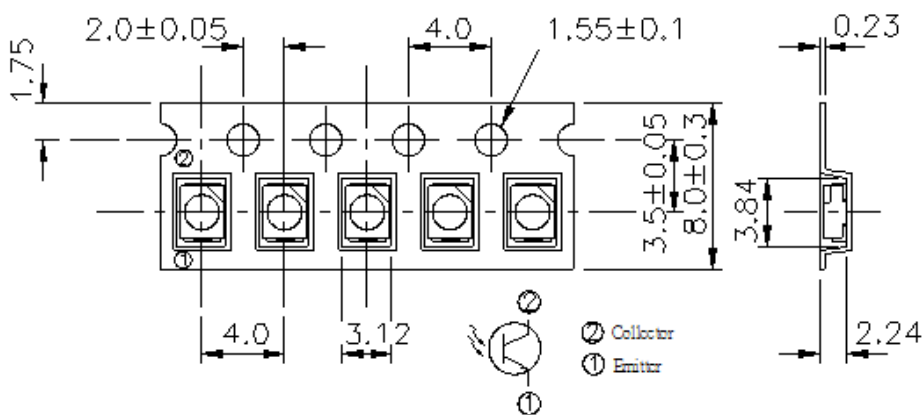

TOLERANCES UNLESS DIMENSION ± 0.1
ANGLE ± 0.5
UNIT:mm

Note: The tolerances unless mentioned is ± 0.1 mm ,Unit = mm

Packing Procedure

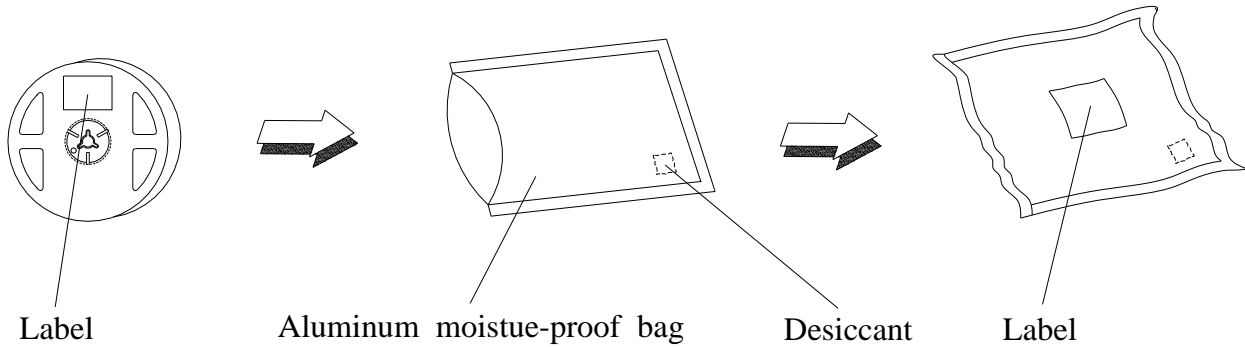

Label Form Specification

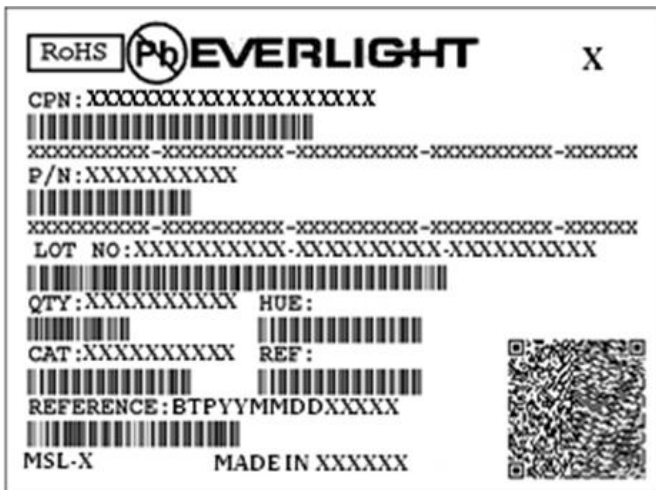

CPN: Customer's Production Number
P/N : Production Number
QTY: Packing Quantity
CAT: Ranks
HUE: Peak Wavelength
REF: Reference
LOT No: Lot Number
MADE IN TAIWAN: Production Place

DISCLAIMER

1. EVERLIGHT reserves the right(s) on the adjustment of product material mix for the specification.
2. The product meets EVERLIGHT published specification for a period of twelve (12) months from date of shipment.
3. The graphs shown in this datasheet are representing typical data only and do not show guaranteed values.
4. When using this product, please observe the absolute maximum ratings and the instructions for using outlined in these specification sheets. EVERLIGHT assumes no responsibility for any damage resulting from the use of the product which does not comply with the absolute maximum ratings and the instructions included in these specification sheets.
5. These specification sheets include materials protected under copyright of EVERLIGHT. Reproduction in any form is prohibited without obtaining EVERLIGHT's prior consent.
6. This product is not intended to be used for military, aircraft, automotive, medical, life sustaining or life saving applications or any other application which can result in human injury or death. Please contact authorized Everlight sales agent for special application request.